

### □ M フォーミング M Forming

記号 Symbol	形名 Type	呼名 Name	寸法 Dimensions(mm)		
			P±1	H±1	e Max.
RLC RD RSD RMO RML RMG	16 25S	M5-5	5	5	1.7
		M5-10		10	1.7
		M5-15		15	1.7
	25 50S	M10-5	10	5	1.7
		M10-10		10	1.7
	50 75S	M12.5-7	12.5	7	2.0
M12.5-10				10	2.0
M15-7		15	7	2.0	
			M15-10	10	2.0

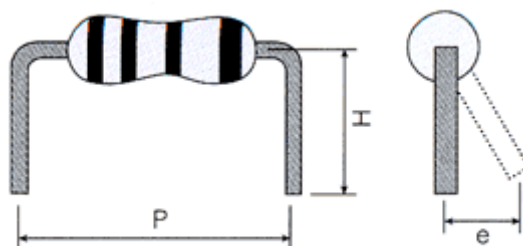

左記以外のフォーミングも可能です  
Other forming types are available

### □ U フォーミング U Forming

形名 Type	呼名 Name	寸法 Dimensions(mm)			
		L <sub>1</sub> Max.	L <sub>2</sub> Max.	H±3	h Min.
RLC 16 RLC 25S	16UD 25SUD	5.5	5.5	30.0	15.0
RLC 25 RLC 50S	25U 50SU	9.5	10.5	30.0	10.0
RD 16, 25S	16UD, 25SUD	5.5	5.5	30.0	15.0
RD 25	25U	9.5	10.5	30.0	10.0
RD 50	50U	14.0	13.0	30.0	10.0

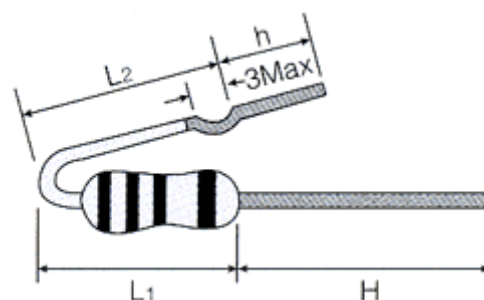

\* UD はキックなしを示す UD : Non Kink

### □ 自立型フォーミング Self-Standing Forming Unit

形名 Type	呼名 Name	寸法 Dimensions(mm)				
		P	H <sub>1</sub>	H <sub>2</sub>	H±3	t <sup>+0.2</sup> <sub>-0</sub>
RLF 1/2S RMO 25	1/2SH10 25H10	10±1	4±1	5±1.0	10	1.2
RLF 1/2B RLF 1S RMO 50 RLC 75S	1/2BH12.5 1SH12.5 50H12.5 75SH12.5	12.5±1	4±1	5±1.0	10	1.2
RLF 1B RLF 2S RMO 75	1BH15 2SH15 75H15	15±1	6±2	5±1.5	13	1.4
RLF 2B RLF 3S RMO 80 RLC 80S	2BH20 3SH20 80H20 80SH20	20±1	10±2	5±1.5	18	1.4
RLF 3B RLF 5S	3BH30 5SH30	30±1	13±2	5±1.5	18	1.4

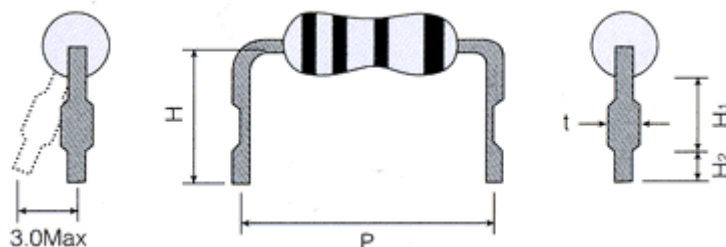

□縦形テーピング Radial Taping

形名 Type	呼名 パナサート PANA-SERT
RD 25	25UCTP
RD 50S	50SUCTP
RLC 25	25TPA
RLC 50S	50STPA

- (1) 累積ピッチ Accumiated Picth- $254 \pm 2$ mm in 20 pitch.  
 (2) 包装単位 Package-2000pcs per BOX as a standard package.

